



TC 32 BUFFALO ICE

tritacarne refrigerato
refrigerated meat grinders



INDUSTRIA 4.0



TC 32 BUFFALO ICE



TC 32 BUFFALO ICE

Optionals: tramoggia gigante, gambe con ruote e piano estraibile
larger feed tray, legs with wheels and removable tray holder

- Tritacarne refrigerato da laboratorio per la massima sicurezza igienica e per impegni gravosi
- Potenti motori HP 4 autoventilati IP 55 per uso continuo.
- Corpo macchina totalmente in acciaio inox AISI 304.
- Impianto refrigerante con gas R290
- Riduttore a bagno d'olio con ingranaggi rettificati e sistema di protezione a doppio paraolio.
- Pratico fissaggio bocca con leva interbloccata (CE)
- Gruppo macinazione ad alta produzione completamente in acciaio inox.
- Collo introduzione quadro per grande produttività anche in seconda passata.
- Refrigerazione su collo, bocca e fondo tramoggia.
- Tramoggia da 21 litri rimovibile interbloccata (CE) con collo fino a zona macinazione.
- Comandi inox IP 67 con inversione e protezione aggiuntiva in silicone intercambiabile.
- Studiata per una facile e veloce ispezione interna

Opzioni:

- Sistema di protezione per uso piastre con foro > 8 mm
- Bocca Unger parziale o totale
- Hamburgatrice Format M.
- Impianto refrigerante 150 Watt.
- Tramoggia gigante da 31 litri.
- Gambe medie con ruote e freno.
- Piano portavassoi inox estraibile.
- Insacatrice continua.
- SRCS Scheda di controllo remoto

- Refrigerated laboratory meat mincer for maximum hygienic safety and for heavy duty
- Powerful 4 HP self-ventilated IP 55 motors for continuous use
- Machine body entirely made of AISI 304 stainless steel
- R290 gas refrigerator
- Oil bath reducer with ground gears and double oil seal protection system
- Practical head fixing with interlocked fixing lever (CE)
- High production grinding head sett completely in stainless steel.
- Square introduction neck for high productivity even in the second pass.
- Refrigeration on the neck, head and hopper.
- Removable interlocked 21 liter hopper (CE) with neck up to the grinding area
- IP 67 stainless steel control buttons with reverse and interchangeable silicone protection
- Designed for quick and easy internal inspection

Optionals:

- Guard system for plates with hole > 8 mm
- Unger head 3 pcs or 5 pcs
- Format M hamburger attachment
- 150 Watt refrigeration system
- Giant 31 liter hopper.
- Medium st steel legs with wheels and brake
- Removable stainless steel tray holder.
- Sausage filler attachment.
- SRCS wifi control board



Comandi
Controls



Optionals



Supporto vassoio
Tray support



Tramoggia gigante
Larger feed tray



Format M
Format M



Gambe con ruote
Legs with wheels



Protezione bocca per piastra con foro
 $\varnothing > 8$ mm
Safety device for $\varnothing > 8$ mm plates.



Kit insacchire
Stuffer kit



Standard o enterprise 1/2 Unger Unger Totale

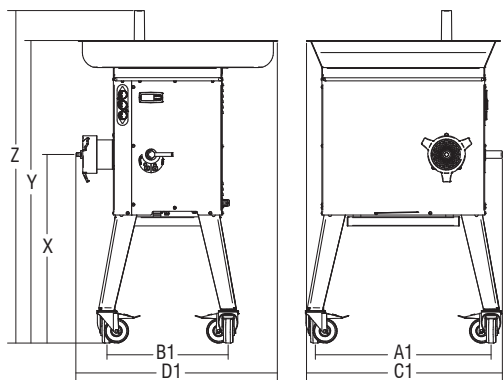

Gambe medie con ruote
Medium legs with wheels

X: 623 mm A1: 581 mm
Y: 1000 mm B1: 501 mm
Z: 1099 mm C1: 648 mm
D1: 666 mm

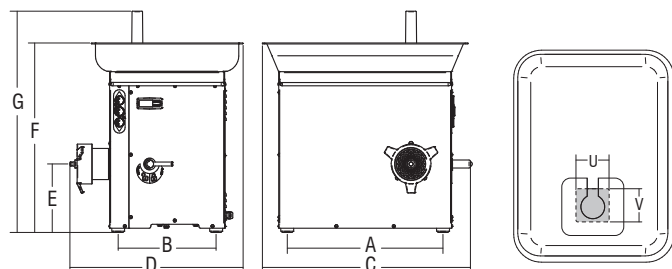

					A	B	C	D	E	F	G	U	V			
	watt/HP	3ph	kg/h.	\varnothing mm	mm	mm	mm	mm	mm	mm	mm	mm	mm	kg	mm	kg
TC 32 Buffalo ICE	3190/4		700	4.5	485	305	648	539	213	590	689	76	76	62	640x760x850	80