

VITO XM Spec sheet



Functionality:

VITO XM cleans your oil in a simple and hygienic way. VITO extracts the oil from the fryer, filters out solid particles, and stores it in its 100l tank.

From there, it can be safely transported. The oil can then either be pumped back into the fryer or disposed of.

VITO is equipped with VITOconnect, which provides you with an online overview of productivity, services, and updates.

Features:

- ▲ Operating temperature up to 200 °C
- ▲ Vacuum filtration
- ▲ Automatic off - VITO has built-in oillevel sensor
- ▲ Automatic safety off - filtration/return after 5min; heater after 30min
- ▲ Integrated heater (for solid fat additional system heater recommended)
- ▲ VITO made out of stainless steel (1.4301) and other food safe materials
- ▲ Hose can be removed by quick connector
- ▲ Filter basket and lance holder are dishwasher safe
- ▲ Lockable castors
- ▲ Network connection (WiFi)

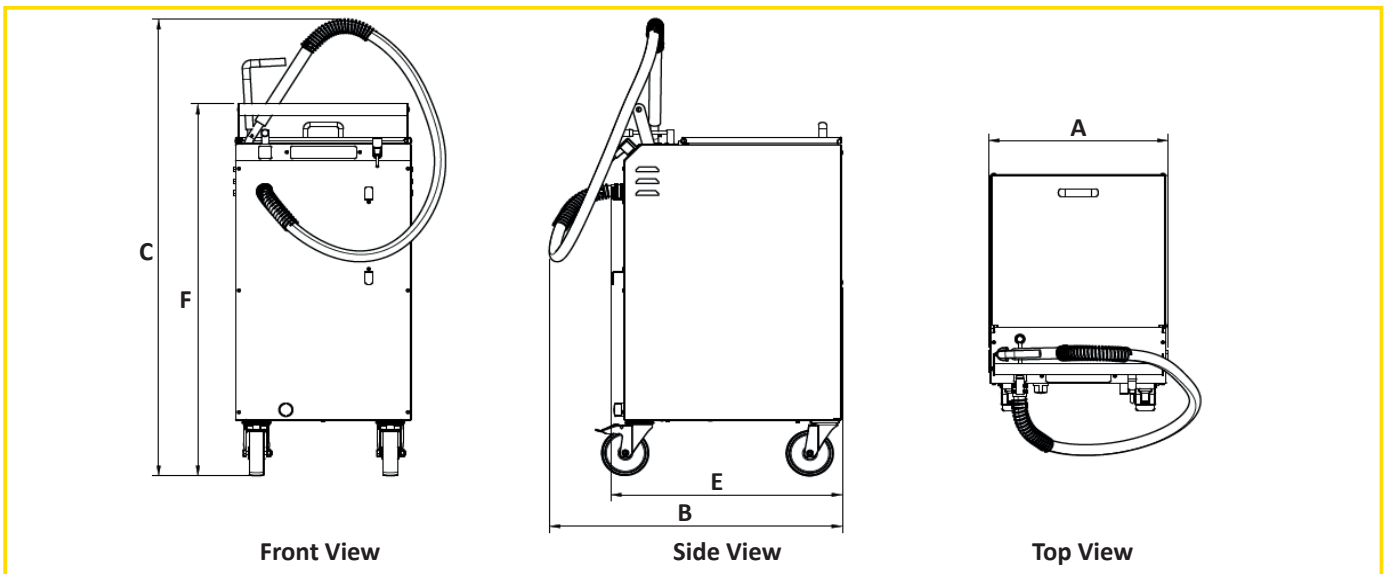

VITO XM technical Data:

	Width A	Depth B	Height C			Depth E	Height F	Hose length
	480 mm	786 to 876 mm	1255 to 1265 mm			622 mm	1031 mm	1500 mm
Filtration power	Filtration efficiency	Particle capacity	Pumping power	Heating power	Max. power	Power connection	Frequency	Fuses inside
up to 30 l/min	5 µm effective/ 20 µm nominal	10 l/10,7 kg*	35 l/min	110 W	1200 W	220 - 240 V, single phase	50-60 Hz	4 AT & 8 AT
Protection	Tank	Weight	Temperature	Material	WiFi			
SK1 (PE)	100 l	65 kg	max. 200 °C	Stainless steel 1.4301	2.4 GHz			

*regular break crumbs

Accessories:

- ▲ Additional system heater for solid fat (130 W)
- ▲ Access to <https://connect.vito.ag>
- ▲ Various particle filters



VITO AG
P: +49 7461 96289-0
info@vito.ag / www.VITO.ag