

# VITO XL

## Spec sheet



### Functionality:

VITO XL cleans your oil in an easy and hygienic way. It extracts the oil out of your fryer, cleans it from particles and stores it inside its 120l tank. From there, it can be safely transported on flat floors. The oil can then either be pumped back into the deep fryer, or simply disposed. VITO is integrated into the VITOconnect system environment. VITOconnect gives you an online overview of productivity, services and updates.

### Features:

- ♣ Operating temperature up to 200 °C
- ♣ Vacuum filtration
- ♣ Automatic off - VITO has built-in oillevel sensor
- ♣ Automatic safety off - filtration/return after 5min; warmer after 30min
- ♣ Integrated warmer (for solid fat additional system heater recommended)
- ♣ VITO made out of stainless steel (1.4301) and other food safe materials
- ♣ Hose can be removed by quick connector
- ♣ Filter basket is dishwasher-safe
- ♣ Adjustable height of the handle and lockable castors
- ♣ Network connection (WiFi)

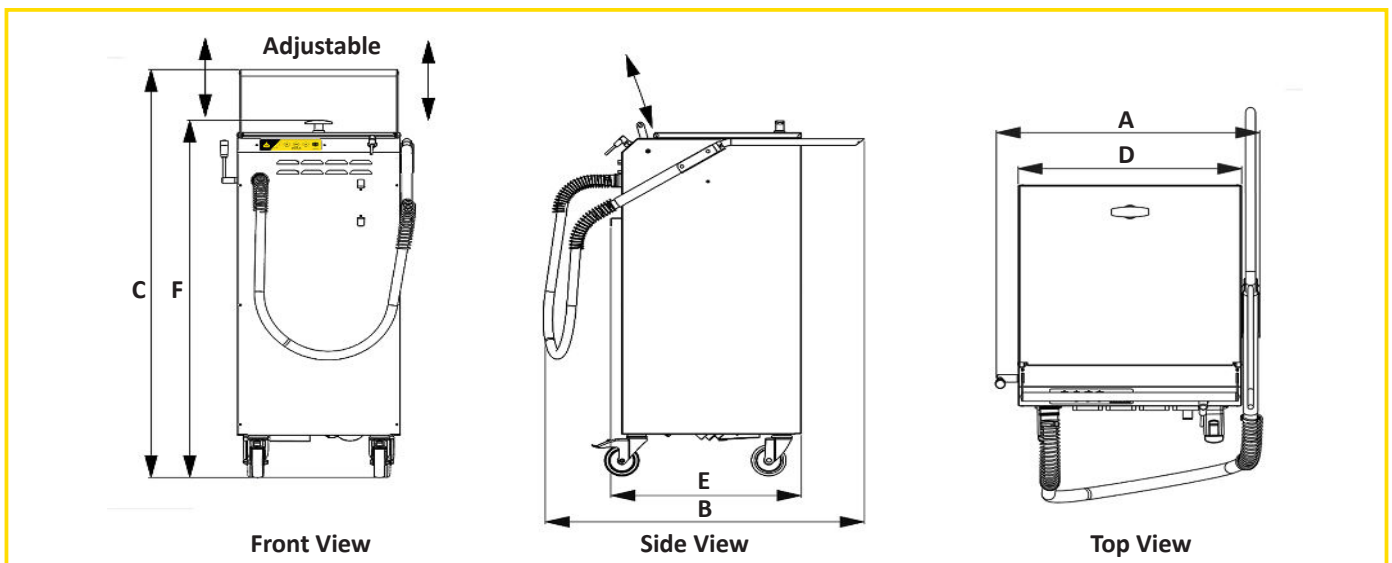

### VITO XL technical Data:

	Width A	Depth B	Height C			Width D	Depth E	Height F
	555 mm	885 mm	1334 mm			470 mm	552 mm	1174 mm
Filtration power	Filtration efficiency	Particle capacity	Pumping power	Heating power	Max. power	Power connection	Fuses inside	Protection
up to 30 l/min	5 µm effective/ 20 µm nominal	10 l/10,7 kg*	35 l/min	110 W	1200 W	220 - 240 V, single phase	4 AT & 8 AT	Protection Earth (PE)
Tank	Weight	Temperature	Material	WiFi				
120 l	64 kg	max. 200 °C	Stainless steel 1.4301	2.4 GHz				

\*regular bread crumbs

### Accessories:

- ♣ Additional system heater for solid fat (130 W)
- ♣ Access to <https://connect.vito.ag>
- ♣ Various particle filters



**VITO AG**  
P: +49 7461 96289-0  
info@vito.ag / www.VITO.ag