

VITO VM Spec sheet



Functionality:

VITO VM cleans your oil in an easy and hygienic way. VITO is placed in the hot oil and filters the oil from suspended particles and bitter substances without supervision. After the set time (standard 4,5 min) VITO stops automatically and your oil is ready to be used. VITO is integrated into the VITOconnect system environment. VITOconnect gives you an online overview of productivity, services and updates.

Features:

- ♣ For 1-4 deep fryers up to 20 l (light to medium sediment)
- ♣ Pressure flow filtration
- ♣ Automatic filtration - VITO stops after set filtration time
- ♣ Automatic safety off - VITO has integrated tilt-switch & heat protection
- ♣ Up to 16 filtration cycles in a row to filter multiple fryers
- ♣ VITO made out of stainless steel (1.4301) and other food safe materials
- ♣ Pump-filter unit and drip pan can be cleaned in dishwasher
- ♣ Network connection (WiFi)
- ♣ Cable holder with snap button
- ♣ Acoustic and visual signals

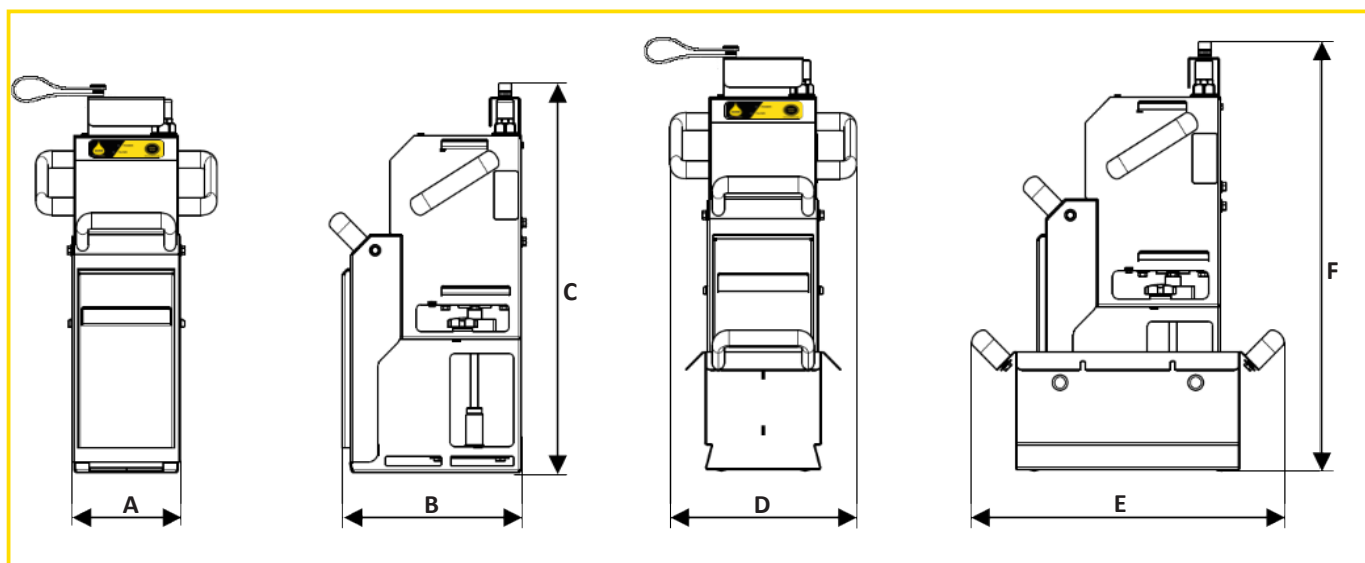

VITO VM technical Data:

	Width A	Depth B	Height C			Width D	Depth E	Height F
	116 mm	191 mm	406 mm			195 mm	324 mm	434 mm
Filtration power	Filtration efficiency	Particle capacity	Work cycle	Suction depth	Max. power	Power connection	Fuse inside	Protection
up to 60 l/min	5 µm effective/ 20 µm nominal	1,3 kg* (1,7 l)	4,5 min (adjustable)	~35 cm	300 W	220 - 240 V, single phase	4 AT	Protection Earth (PE)
WiFi	Total weight	Weight	Temperature	Material				
2.4 GHz	8,9 kg (with drip pan)	7,7 kg (without drip pan)	max. 200 °C	Stainless steel 1.4301				

*regular bread crumbs

Extensions & Accessories:

- ♣ Access to <https://connect.vito.ag>
- ♣ Brackets to accommodate all fryer types
- ♣ Particle filters

