

Il Carrettino Classic

H 208
P 128
L 200

Ice cream & Pastry

A G	C	TN Chiller	TB Freezer	TB/TN Dual Temp	TC Heated	TC/TN Hot&Cold	N Non-refrigerated
RS - Static							
RV - Ventilated			•				
RS/TC S - Static and Dry Heat convertible							
RV/TC S - Ventilated / Dry Heat convertible							
HUR - Meat							
CH - Chocolate							
TC S - Dry Heat							
TC BM - Bainmarie							
N - Non-refrigerated							

Installation
Plug-in

Configuration

- Scoop washer with water tap
- Tanks for water
- Sun curtain

Temperature
-16/-14 °C

Refrigerant
R290

Refrigeration
Ventilated

Compressor
Hermetic

Defrost
Hot gas

Climate class
4

Upper class
Tempered single

Front glass
Tempered single

Side glass
Tempered single

Rear closing system
Tilting panel

Work top
Stainless steel

Lighting
Led 5700 K

Equipment handling
2 Ray wheels and
one pivoting wheel with brake

Installazione
Plug-in

Configurazione

- Lavaporzionatore con rubinetto
- Tancine per acqua
- Tenda decorativa parasole

Temperatura
-16/-14 °C

Refrigerante
R290

Refrigerazione
Ventilata

Compressore
Ermetico

Sbrinamento
Gas caldo

Classe climatica
4

Vetro superiore
Singolo temperato

Vetro frontale
Singolo temperato

Vetri laterali
Singolo temperato

Chiusura posteriore
Ribaltina basculante

Piano di servizio
Acciaio inox

Illuminazione
Led 5700 K

Movimentazione
Ruote con raggi (2) + ruota (1)
pivottante con freno

Internal color
Colore interno

Inox

Front / sides colours
Colori frontale / fianchi

Yellow Graphic

Brown Graphic

White

Black



Il Carrettino

Classic

RV TB

External dimensions (LxDxH) Dimensioni esterne (LxPxH)	2000 x 1285 x 2081 mm
Capacity (gross / net) Capacità (lorda / netta)	-
Weight (net) Peso (netto)	205 kg
Refrigeration Refrigerazione	Ventilated Ventilata
Refrigerant Refrigerante	R290
Climate class Classe climatica	4
Operating conditions Condizioni ambientali	30 °C / 55 %RH
Energy class Classe energetica	C
Product temperature Temperatura prodotto	-16/ -14 °C
Compressor (q.ty - type) Compressore (q.tà - tipologia)	1 - Hermetic 1 - Ermetico
Defrost Sbrinamento	Hot gas Gas caldo
Power supply Alimentazione	230 V / 1 Ph / 50 Hz
Electrical input (nominal) Assorbimento elettrico (regime)	470 W / 2,2 A
Electrical input (defrost) Assorbimento elettrico (sbrinamento)	750 W / 3,5 A

Technical sheet about models whit condensing unit included with air cooled
Dati tecnici riferiti a modelli con unità a bordo con condensazione ad aria

Setup - Stainless steel containers

Allestimento - Vaschette gelato in acciaio inox

Display

Vasca espositiva

4,75 Lt	260 x 157 x 170H	10
5 Lt *	360 x 165 x 120H	6 + (6)

* Piled up double row Doppia fila di riserva

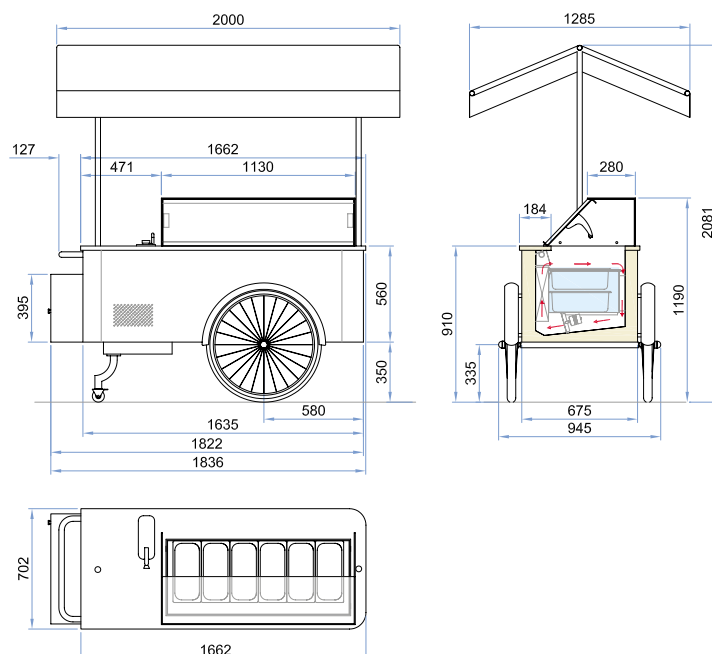

Display - piled up double row - 5 Lt
Vasca espositiva - doppia fila di riserva

